

## About F5

F5 smart ultrasonic flow meter combines ultrasonic flowmeter and Internet +, adopts advanced modular all-in-one design and TVT time measurement technology with independent menu operation and LCD backlight display.

The unique digital signal processing technology enhances the anti-interference ability. Combined with the high-accuracy clamp on/insertion flow sensor, the measurement signal is more stable, the measurement is more accurate, the installation is simpler, and the maintenance is easier.

It supports the Modbus, Fuji communication protocol, OCT, relay, 4-20mA output, RS485, M-BUS (optional) communication interface used in the current industrial occasions, and can be flexibly selected in combination with the site conditions.

It supports WiFi distribution network icloud service function, through WeChat public number, the data can be viewed in real-time by mobile, PC terminal, which makes data reading, on-site maintenance more convenient.



### 1. Product Characteristics

The meter supports WIFI, OCT, relay, 4-20mA output, and has RS485, M-BUS communication interface used in the current industrial occasions

### 2. Gentos icloud system service

WiFi connected icloud service. Users can inquire data on mobile terminal in real time and know each information at any time. Users can upgrade application by remote control(consult manufactures for details).

### 3. Energy efficiency monitoring

The meter has energy efficiency monitoring system. The measured data information can be monitored in real time and data curve can be observed in real time, generating data report.



### 4. Built in SD card data storage function

The meter has a built-in 8G big capacity SD card, with strong data acquisition and storage function. It collects the flow, flow rate, net accumulation, positive accumulation and negative accumulation corresponding to each time to ensure no data loss.

### 5. Easy installation

The meter supports wall mount installation and clamp on pipe installation. The clamp on pipe installation installs meter transmitter on measured pipe line, thus reducing the trouble of cable routing, which will save so much time and energy. And then the meter coordinates icloud service, every data will be great clear.

## Applications

It can be widely used in saving-energy, air-conditioning, building automation system, data central, energy audit, HVAC, etc





The meter has Gentos icloud energy efficiency monitoring function. Users can log in the account and password that we offer to scan all data on WeChat public number-----SMART METERS and website. Users can inquire directly and clearly all data of each meter, and can observe its corresponding data curve and data report according to related data. Also, F5 can add meter billing system, has independent background management page. It is easy to set cost unit price, cost data and consumption. It can generate monthly cost bill and cost report.

Central air-conditioning is widely applied in business comprehensive complex, whose energy consumption covers more than 50% of energy consumption of the whole building complex. Thus, China proposes to create green saving-energy building environment. The actual energy consumption of air-conditioning is closely related to the interests and benefits of all users. According to the survey and statistics, because the air-conditioning fee is charged on the basis of accumulation, this phenomenon leads to a great waste of energy. The difficult problem of central air-conditioning billing perplexes property companies all the time. They want to achieve accurate metering and reasonable billing like water meters, electricity meters and gas meters. We follow the law of market economy, and pay as much as you use, which makes all users satisfied, build saving-energy awareness, promoting building saving-energy.

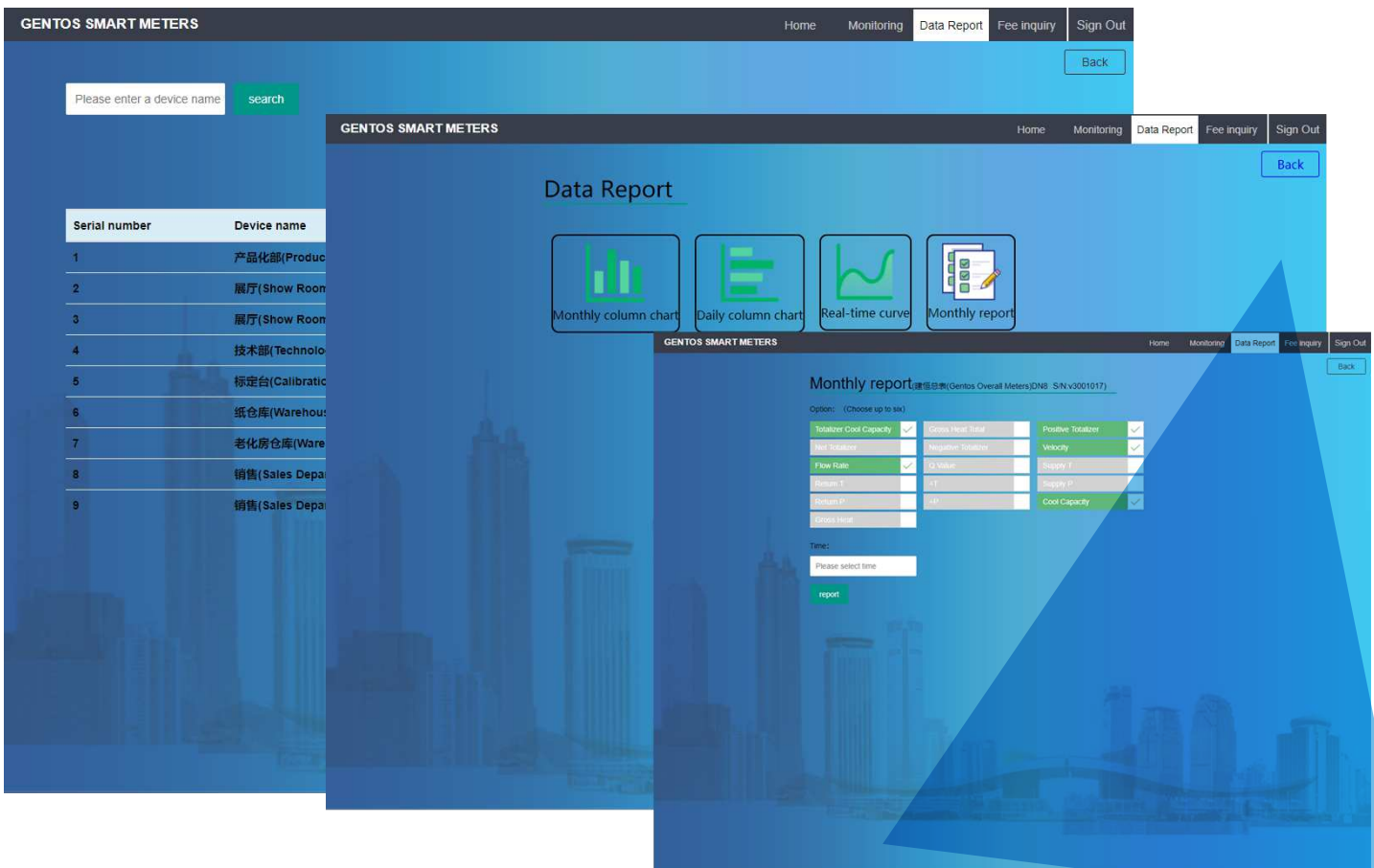

## Specification

Performance specifications	
Flow range	$\pm 0.03\text{ft/s} \sim \pm 16\text{ft/s}$ ( $\pm 0.01\text{m/s} \sim \pm 5\text{m/s}$ )
Accuracy	$\pm 1.0\%$ ( $\pm 1.6\text{ft/s} \sim \pm 16\text{ft/s}$ ) ( $\pm 0.5\text{m/s} \sim \pm 5\text{m/s}$ )
Pipe size	Clamp-on: 1''~48'' (25mm~1200mm)
Fluid	Water.
Pipe material	Carbon steel, stainless steel, PVC.
Function specifications	
Outputs	OCT Pulse output: 0~5000Hz. Analog output: WIFI, 4~20mA, max load 750 $\Omega$ .
Communication interface	RS485 MODBUS
Power supply	10~36VDC/1A
Keypad	16(4 $\times$ 4)key with tactile action
Display	20 $\times$ 2 lattice alphanumeric, back lit LCD.
Temperature	Transmitter: 14 $^{\circ}$ F~122 $^{\circ}$ F (-10 $^{\circ}$ C~50 $^{\circ}$ C) Transducer: 32 $^{\circ}$ F~176 $^{\circ}$ F (0 $^{\circ}$ C~80 $^{\circ}$ C)
Humidity	Up to 99% RH, non-condensing
Physical specifications	
Transmitter	PC/ABS, IP65.
Transducer	Encapsulated design, IP68.
Transducer cable	Standard cable length: 30ft(9m).
Weight	Transmitter: approximately 0.7kg; Transducer: approximately 0.4kg

## Transducer Installation Methods

### V method measuring pipe size : 25mm-400mm

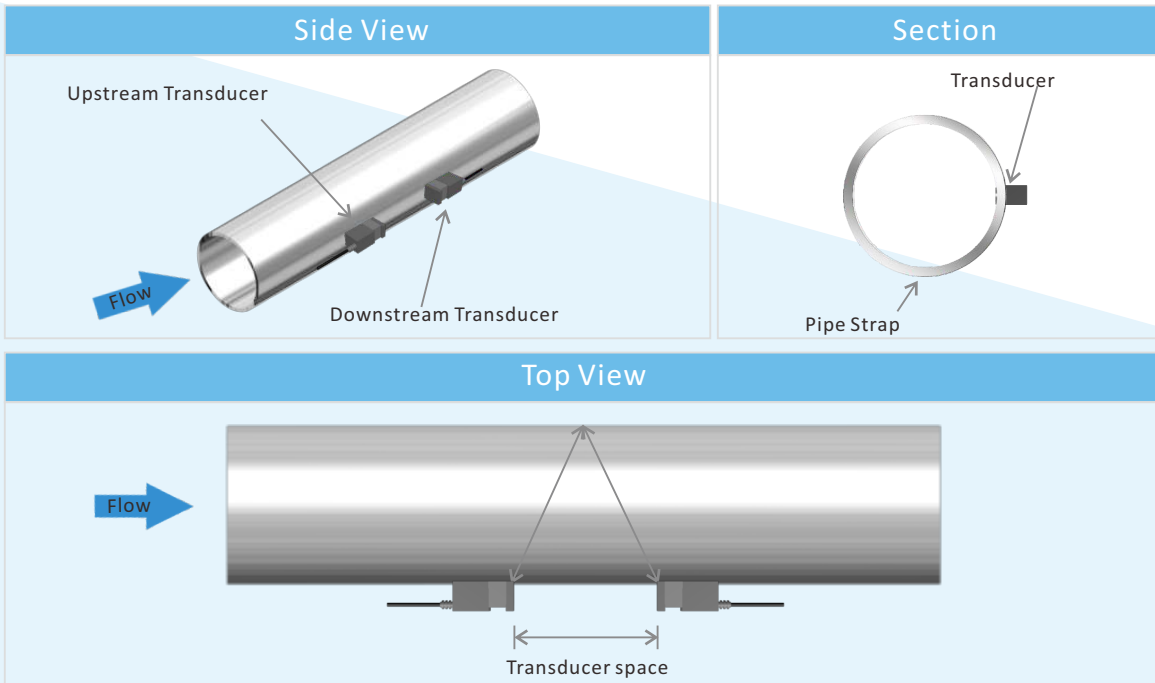

### Z method measuring pipe size: 100mm-800mm

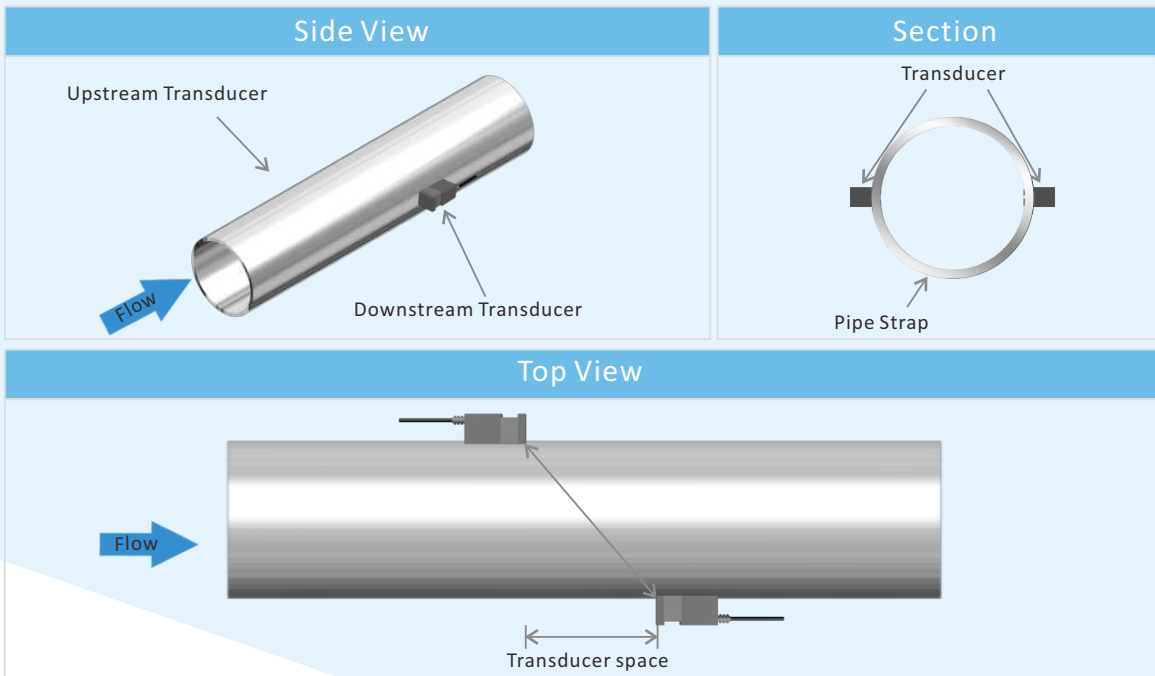

## Wiring Diagram & Transmitter Dimensions

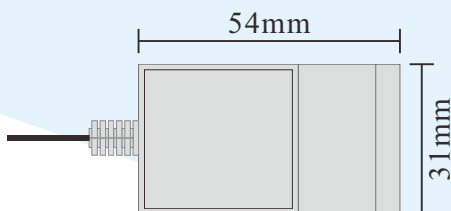
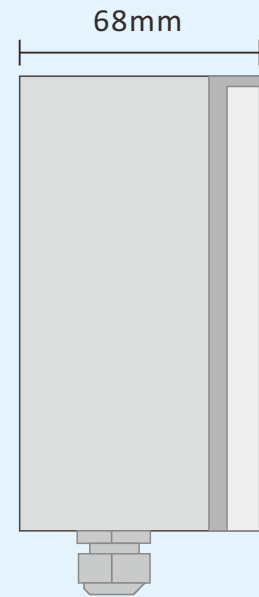
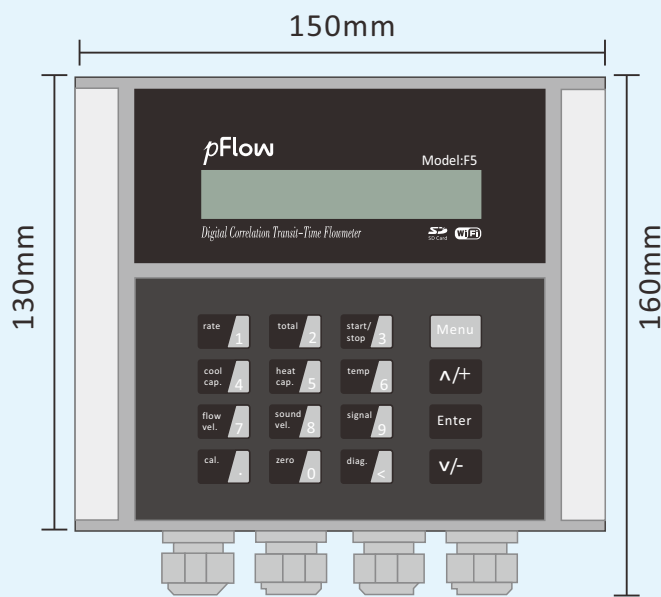
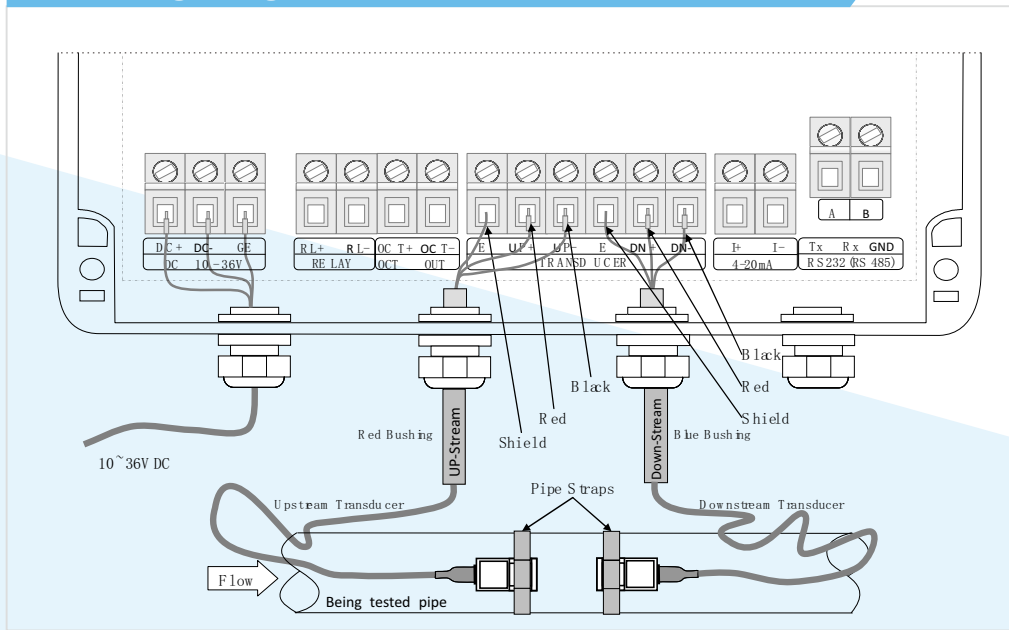

## Ordering Information

Description				
F5	Digital Correlation Transit Time Flowmeter Installation method: wall mount Transmitter: Flow Range: $\pm 0\text{ft/s} \sim \pm 16\text{ft/s}$ ( $\pm 0\text{m/s} \sim \pm 5\text{m/s}$ ) Accuracy: $\pm 1.0\%$ ( $\pm 1.6\text{ft/s} \sim \pm 16\text{ft/s}$ ) ( $\pm 0.5\text{m/s} \sim \pm 5\text{m/s}$ ) Repeatability: 0.3% Pipe Size Range: 1"~48" (25mm ~ 1200mm) Keyboard: 16 (4x4) touch keys Display: 20x2, alphanumeric, backlit LCD Power supply: 10-36V DC@1Amax Transmitter enclosure: IP65, ABS/PC enclosure Temperature: $-20^{\circ}\text{C} \sim 50^{\circ}\text{C}$ Output: WIFI, OCT pulse output 0-10KHz, Relay output, 4-20mA optional Communication: RS232, Modbus Protocol Temperature: $-40^{\circ}\text{F} \sim +140^{\circ}\text{F}$ ( $-40^{\circ}\text{C} \sim 60^{\circ}\text{C}$ )			
Output mode				
1	OCT output, Relay output, RS232, 4-20mA output			
2	OCT output, Relay output, WIFI, RS485, 4-20mA output			
Type of transducers				
CP	Clamp on transducer, Operating temperature: $32^{\circ}\text{F} \sim +140^{\circ}\text{F}$ ( $0^{\circ}\text{C} \sim +60^{\circ}\text{C}$ )			
W	Insertion transducer, Operating temperature: $-40^{\circ}\text{F} \sim +176^{\circ}\text{F}$ ( $-40^{\circ}\text{C} \sim +80^{\circ}\text{C}$ )			
Transducer Cable Length				
030	Standard 30ft (9m)			
xxx	Maximum lengthen to 305m(1000ft), per 5m is a lengthen unit.			
Standard Model: F5-2-CP-030 Description: standard enclosure with Clamp-on transducers, OCT output, Relay output, WIFI, RS485, 4-20mA output				
Packaging				
				
Transmitter	Transducer	Pipe strips	Coupling compound	SD card